

CV™ SERIES



**THE NEW
INTERNATIONAL® CV™ SERIES.**





INTRODUCING THE INTERNATIONAL® CV™ SERIES
**BUILT TO ELEVATE
YOUR BUSINESS**

6.6L | 350 HP | 700 LB. - FT. TORQUE



COMMERCIAL
EXPERTISE



COMMERCIAL
GRADE



FIT TO UPFIT



DRIVERFIRST™



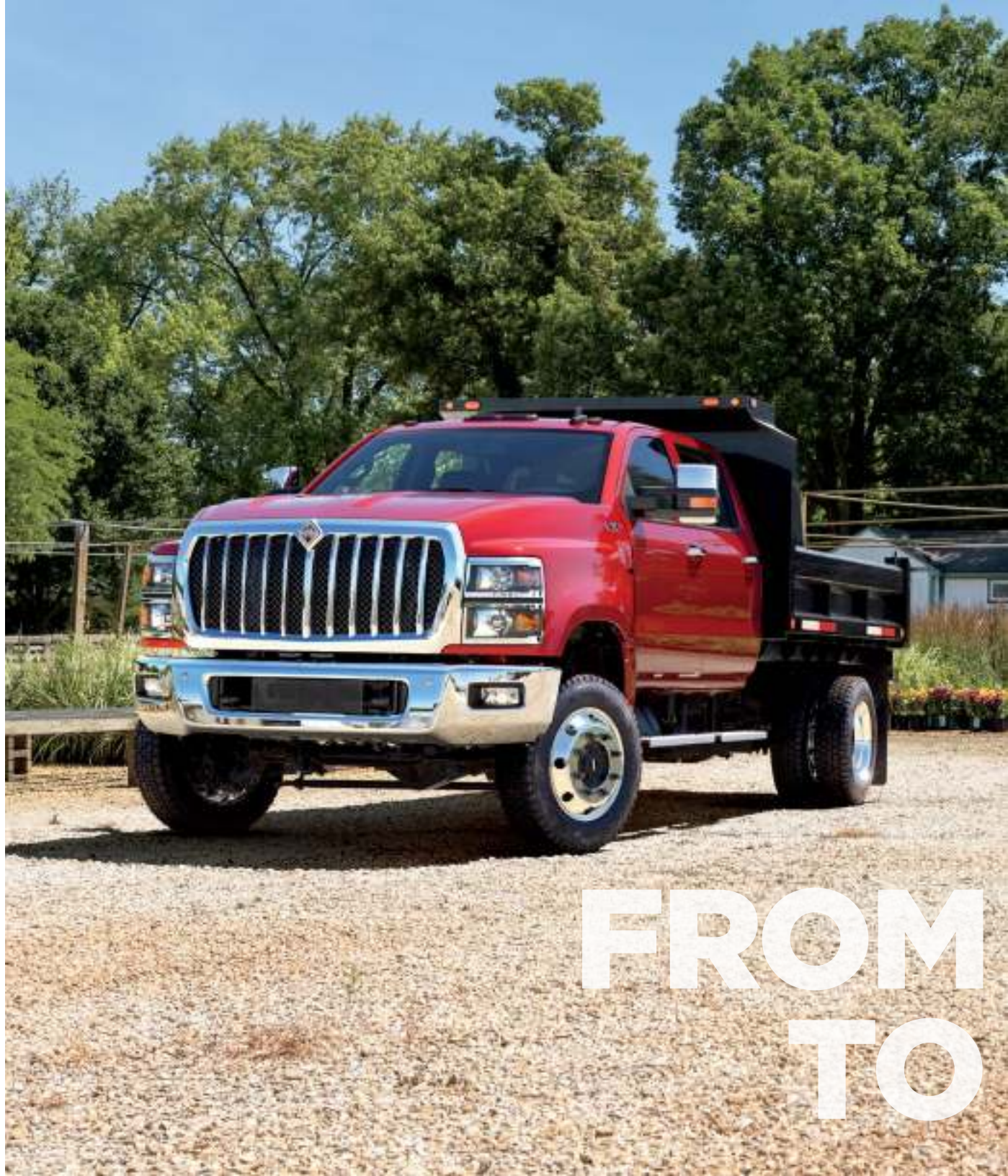

WE UNDERSTAND WHAT IT
TAKES TO BUILD A BUSINESS.

We know new equipment is a big investment. We know, if you're going to take that next step, you need a sure thing. A truck that will not let you down. A truck that will take your business to new heights.

That's why we built the CV™ Series. For people like you. Because you've only just begun.

FROM
TO



**START-UP
SCALE-UP**



For those who are ready to take the next step with their business, reach for the next rung, expand their capabilities and open up new possibilities, introducing the International® CV™ Series. It's the only class 4/5 truck designed, distributed and supported by a manufacturer that specializes in commercial trucks.

This means the largest commercial dealer network with more dedicated truck bays and diesel technicians than anyone else. It's designed for upfitting with a straight frame and a wide range of wheelbase options plus a DriverFirst™-inspired interior with exceptional visibility, excellent maneuverability plus ride-and-handling that's second to none. The CV Series—ready when you are.





HV
INTERNATIONAL

A SMARTER APPROACH TO SERIOUS WORK

MV
INTERNATIONAL

DELIVERING DAY-IN, DAY-OUT

**BORN AND BRED
AT THE WORK SITE**



CV
INTERNATIONAL

ELEVATE YOUR BUSINESS

HX
INTERNATIONAL

UNSTOPPABLE ENDURANCE

International® Truck is known for building some of the most rugged, powerful and hard-working trucks on the planet and the CV™ Series continues this tradition. Just like its bigger brothers, the CV Series features TEM-ready straight frame rails, engine and service points that are easy-to-access for both technicians and crew, plus a DriverFirst™ interior that's comfortable and productive. And like every International® Truck, the CV Series also brings vast capabilities, rock-solid uptime and unlimited possibilities.





DEALERSHIPS THAT UNDERSTAND THE TRUCK BUSINESS

It's one thing to build a commercial-grade truck, it's another to actually support it with commercial expertise. International® Truck dealerships are well-versed in the commercial vehicle language and every team member, from the sales floor to the service bay, understands the needs of commercial vehicle customers. Whether

it's working closely with an upfitter or repairing a diesel engine, International dealerships know how to get it done—and done right. Plus, with the industry's largest commercial dealer network and over 7,600 service bays, no matter where you are, if you need service, help is likely to be nearby.



THE POWER OF INTERNATIONAL®

- ▶ Industry's largest commercial dealer network with more dedicated commercial truck bays than Ford, Chevrolet or Ram
- ▶ 98% of parts available between Parts Distribution Centers (PDCs) and dealer inventory
- ▶ Commercial diesel-trained technicians:
 - Over 8,000 in North America
- ▶ Dealership sales staff that specialize in commercial sales and can help you configure a truck that's tailored to your business needs
- ▶ Application Engineering Team
 - Vocational engineering experts ready to help you design a custom configuration for your application



WE HAVE YOUR BACK SO YOU CAN KEEP MOVING FORWARD

Your International® dealer is one of the best in the business and part of the industry's broadest, most capable parts and service network.



DIAMOND EDGESM CERTIFIED INTERNATIONAL[®] TRUCK DEALERS

This select network of International dealer service departments has passed rigorous parts and service certification guidelines to provide you with faster turnarounds, immediate parts availability and a higher level of servicing expertise. Their ongoing pledge is to maximize your uptime and deliver a best-in-class customer experience.

YES, WE'RE

OPEN

Saturday

488

Locations

Sunday

47

Locations

720

DEALER LOCATIONS

8,000+* **7,600+***
TECHNICIANS SERVICE BAYS



*North America





COMMERCIAL-GRADE DESIGN, PRODUCTION AND POSSIBILITIES

It's important to note that the CV™ Series is not consumer-grade. It's not designed for average jobs. It's not built in a factory that makes pickup trucks. This is a commercial-grade vehicle built for commercial-grade needs. International engineers started with a clean sheet of paper with one mission: create the toughest, most-capable, most upfit-friendly class 4/5 truck at the work site. This means a heavy-duty, gear-driven transfer case, a single, high-strength frame rail, an available air ride suspension, easy-to-reach maintenance points and a long list of heavy-duty details only found on a truck designed by commercial truck engineers.

COMMERCIAL GRADE FROM THE WHEELS TO THE CLEARANCE LIGHTS

- ▶ Segment-only gear-driven transfer case. Provides extra strength (no chains to stretch)
- ▶ Painted chassis for enhanced longevity and corrosion resistance
- ▶ Single high strength low alloy steel (50,000 PSI yield strength) frame rail is ready for easy upfitting
- ▶ GVWR up to 23,500 lbs
- ▶ Optional air ride suspension with engine-mounted compressor can be used to adjust height and provide a smooth ride for cargo protection and crew comfort
- ▶ Commercial-grade Hydromax Braking System
- ▶ 4-inch bumper extension is available for robust front-end, grille and radiator protection

FORWARD-TILTING COMMERCIAL HOOD IS EASY TO OPEN



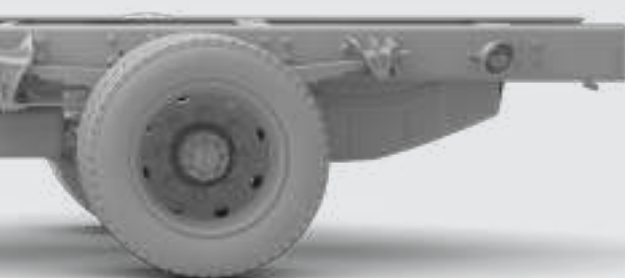

1. The Forward-Tilting Hood provides easy access to the engine and routine service points
2. Tool-less headlight bulb replacement
3. Standard, self-cleaning, high-grip steps are ideally placed so drivers and passengers can enter and exit the cab with ease.
4. The DEF (Diesel Exhaust Fluid) tank refill placement is mounted by the passenger side door to help avoid mixing the wrong fluids and allows the tank to be filled without opening the hood.



A COMMITMENT TO SAFETY

50-degree wheel cut offers excellent maneuverability which can help you avoid costly incidents at crowded work sites

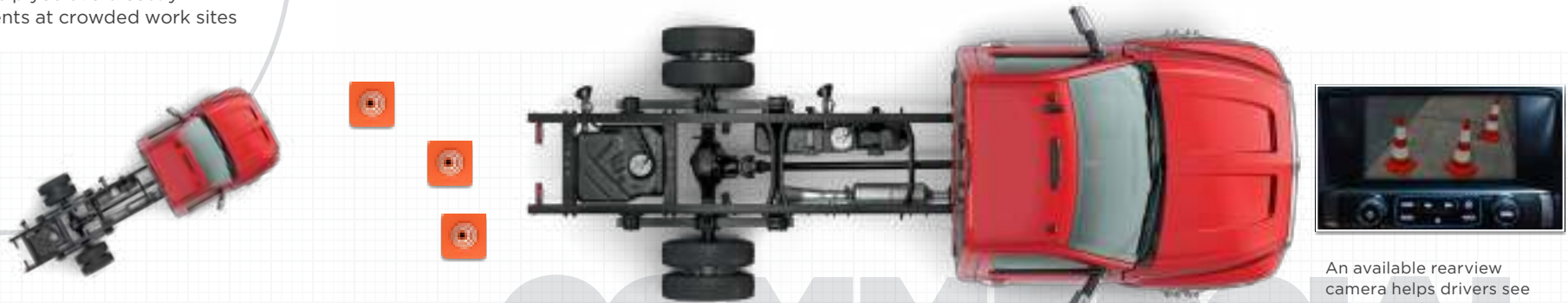

An available rearview camera helps drivers see potential obstacles when backing up

COMMERCIAL GRADE BRAKING POWER

- ▶ Hydromax Braking System
- ▶ Bosch Split system with Traction Control
- ▶ Four channel ABS

COMMERCIAL GRADE BRAKES

The Trailer Brake Controller helps drivers maintain control while towing



Integrated hood safety latch helps prevent the hood from blowing down on windy days



The folding side mirrors can include LED turn indicators plus rear-facing LED lights to illuminate cargo and equipment



A WHEREVER, WHENEVER KIND OF ATTITUDE.

The CV™ Series was tested in the same extreme environments as all of our commercial trucks.

**COLD WEATHER TESTING (-40*)
FAIRBANKS, ALASKA**

**SHAKER TESTING
NAVISTAR ENGINEERING VALIDATION CENTER
MELROSE PARK, IL**

**DURABILITY TESTING
NAVISTAR PROVING GROUNDS
NEW CARLISLE, INDIANA**

**HIGH ALTITUDE TESTING (12,000 FT)
LOVELAND PASS, COLORADO**

**EXTREME TEMPERATURE TESTING (115*)
APACHE, ARIZONA**



The CV Series was durability tested in New Carlisle, Indiana and built in Springfield, Ohio on the same line as some of the most powerful trucks on the road including: the International® MV™ Series and HV™ Series

SPRINGFIELD, OHIO

The durability testing of the CV Series was also commercial grade—way beyond what is done for pickup trucks. From the heights of the Rocky Mountains, to the heat of the Arizona desert and the bitter cold of Alaska, the CV Series powered through it all thanks to commercial-only features like a forward-tilting hood for better access to routine service points, a 50-degree wheel cut for maneuverability and an impressive Hydromax braking system for superior stopping ability.



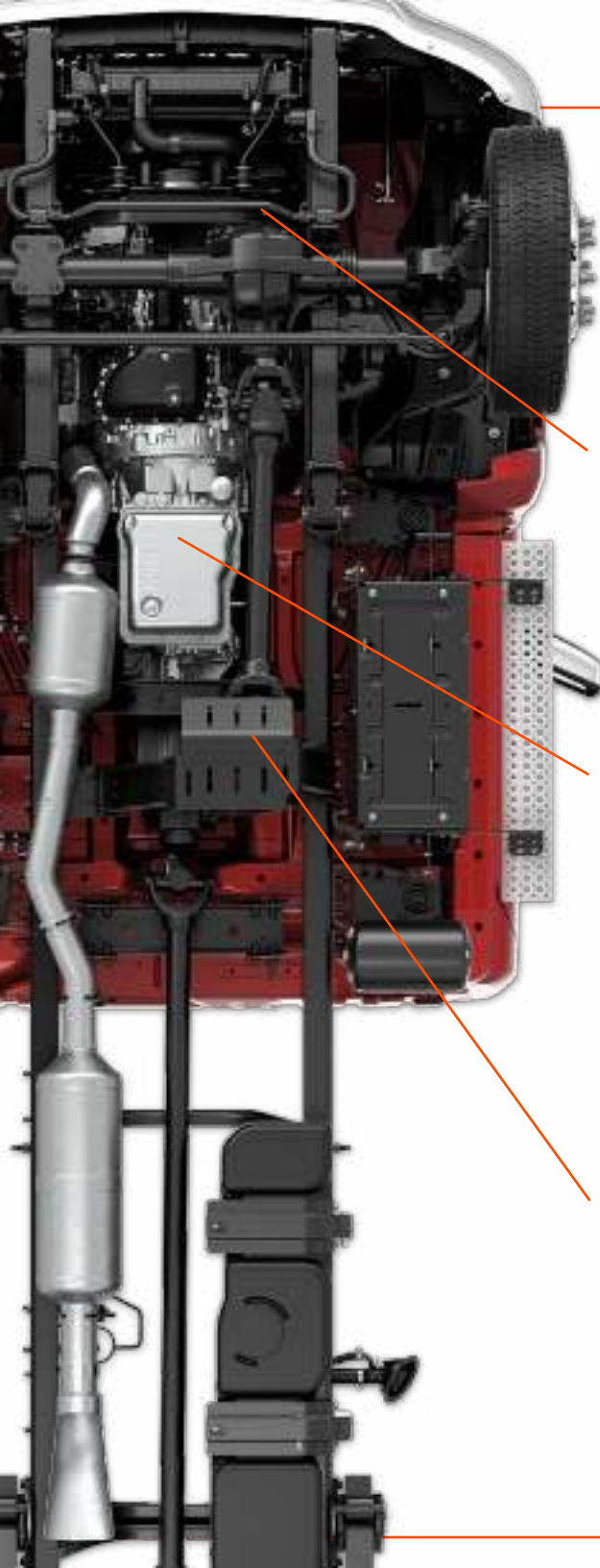

The CV™ Series is powered by one of the most rugged, trusted and thoroughly-tested engine/transmission combinations in the industry. During the CV Series validation process, this powertrain proved itself over and over — from the brutal cold of Alaska to the punishing heat of Arizona and the extreme altitude of the Colorado Rockies. Over one million examples of this legendary duo are currently on the road making deliveries, hauling gear and getting the job done.

1 INTERNATIONAL® 6.6 ENGINE

With 700 ft-lb of torque on tap, the CV Series has the muscle to pull, haul and carry the heaviest of loads.

- ▶ 350 HP, 700 ft-lb of torque
- ▶ Optional engine-mounted air compressor
- ▶ Diesel exhaust brake
- ▶ Remote Start with Keyfob — includes anti-theft deterrent system
- ▶ Optional 120v/800-watt block heater

2 6-SPEED ALLISON TRANSMISSION

As the largest manufacturer of medium and heavy-duty fully automatic transmissions, Allison has a long and proven history in commercial trucks. It's a transmission you can trust to help you take care of business.

- ▶ Legendary reliability and strength
- ▶ Available PTO (Power Take Off) capability to run auxiliary equipment
- ▶ 1000/2000 series
- ▶ Available vocation codes include: Highway Series (HS), Rugged Duty Series (RDS), Emergency Vehicle Series (EVS), Motorhome Series (MH)

3 CONFIDENT 4X4 CAPABILITY

For demanding applications that require access to challenging job sites.

- ▶ Meritor gear-driven transfer case — more durable than chain-driven
- ▶ Heavy duty front axle





NEXT-LEVEL CAPABILITY





BRING MORE TO THE TABLE



SERVICE BODY

Thanks to a straight frame and an available clean CA, the CV™ Series is ready to be upfitted

UTILITY BUCKET LIFT

Need a bucket truck? Between our expert dealers, reliable TEMs and the International Truck Specialty Centers, the CV Series is designed to be easily modified—no matter how complicated the application

When you build commercial vehicles for as long as we have, you learn a thing or two about what businesses need. That's why the CV™ Series has straight frame rails and is available with a clean Cab-to-Axle (CA) package.



THE CV™ SERIES IS READY TO ACCEPT NEARLY ANY BODY—FROM A CONTRACTOR'S DUMP TO A FLATBED—WITHOUT ANY SPECIAL MODIFICATIONS OR REINFORCEMENTS.



SERVICE



UTILITY



DUMP



AMBULANCE



PLOW



TOW



ROLL-BACK



REFRIGERATOR / DRY VAN

DUMP

The CV Series offers a GVWR of up to 23,500 lbs to accommodate extra tools, equipment, and payload requirements of the most robust applications





1

2

4

3

5

6

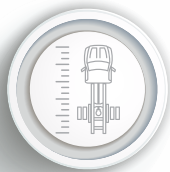

FIT TO BE UPFITTED

When customers choose International®, they know the upfit process will be simple and straight-forward. The CV™ Series is no exception. Customers can spec the CV™ Series exactly to their liking whether it's different fuel tank options, wheelbase options—even different exhaust locations—whatever the customer needs, the CV Series can accommodate



WE'LL WORK WITH YOU SO YOU CAN GET TO WORK

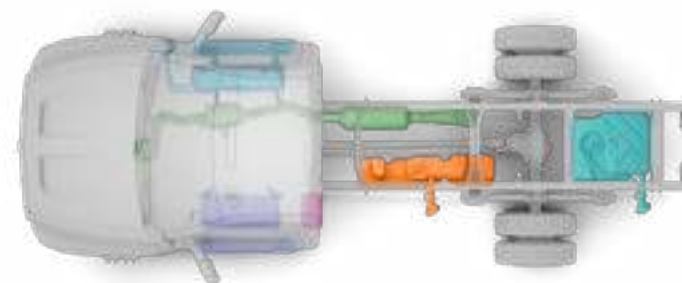

▲ READY TO ROLL

Standard holes for a snow plow mount bracket are pre-drilled into the front frame of the CV™ Series.

SIMPLICITY EQUALS FLEXIBILITY

- 1 Dual battery box is located under the cab. An optional third battery is available for body mounting
- 2 Huck® Bolt chassis fasteners provide consistently superior clamping force without re-torquing, and won't come loose even in extreme environments
- 3 Straight frame rails with no rivets on top flange with a clean CA for easy body mounting
- 4 Optional exhaust outlets available to suit vocation and body
- 5 Fuel tank options:
 - Available 40-gallon After Frame fuel tank (behind rear axle)
 - 25-gallon saddle tank
 - Available dual tanks (25 and 40 gallons respectively)
- 6 Multiple wheelbase options to suit almost any application (7 for day regular and 3 for crew)

International® Truck Specialty Centers

Depending on the application, some post-production modifications are more complicated than others. In cases like these, there's no better place to go than an International Truck Specialty Center. Fully owned and operated by International Truck, our experts provide quick, efficient and cost-effective custom engineering solutions. The CV Series is the only truck that can take advantage of this level of customization within the segment and depending on what you need, it may prove invaluable.

- ▶ Modifications covered under manufacturer's warranty
- ▶ Process supervised by International engineers to ensure factory production-level quality
- ▶ Expertise to identify and resolve issues quickly





SMOOTH OPERATOR



The CV™ Series offers an air ride rear suspension to provide both a smooth ride and height flexibility. In many cases, delicate cargo — from produce to appliances — cannot be jostled during transportation or they risk being damaged. Carriers of these products have long relied on air suspensions to ensure an unscathed delivery.

Emergency vehicles require a gentle ride to keep patients calm and comfortable. The CV™ Series offers an available air ride rear suspension that can keep things smooth and steady, plus the ability to adjust the ride height for easy loading and unloading of stretchers.





COMFORT ZONE MEETS WORK ZONE

DRIVERFIRST™ INTERIOR

The CV™ Series is built to handle whatever the job site throws at it. Supportive, high-wear cloth seats keep your crew comfortable. Inlaid, triple seal doors reduce outside road noise. All controls are designed to be easy-to-operate while wearing gloves and plenty of storage options help keep you organized, including an available center console with hanging file folder capability. Smart, quiet and strong, the CV Series is the ultimate workplace solution.







ROOM FOR GROWTH



Driver comfort is critical to get the job done smoothly and efficiently. Seats should be supportive and comfortable for long stretches of time and all controls must be placed in a way that is logical and intuitive.

We call this our DriverFirst™ philosophy.

The CV™ Series offers drivers and passengers automotive-like comfort, featuring premium interior finishes and outstanding ergonomics. Multiple infotainment options are available including an 8" color touch screen with navigation and, for the first time in an International® truck, Apple CarPlay and Android Auto are available.



4



6



7



5



8

A FIELD OFFICE WITH PERKS

1. The CV™ Series offers comfortable, three-across seating.
2. The center seat back can be lowered and used as an armrest and beverage holder.
3. The seat bottom cushion provides additional storage.
4. The Trailer Brake Controller helps drivers maintain control while towing.
5. All controls are within easy reach and can be operated while wearing gloves.
6. The key fob includes Remote Start to help pre-heat the engine and cabin on cold days.
7. The CV Series is the first International Truck to offer Apple CarPlay and Android Auto.
8. Drivers can expect automotive-like levels of comfort including an available leather-wrapped steering wheel with fingertip controls.



CONFIGURED TO MAKE THINGS EASIER, SAFER AND COMFORTABLE

- ▶ Auto-dimming rear view mirror is available
- ▶ Wide Load Side Mirrors with manual folding/extending are standard. Powered/heated side mirrors with integrated turn signal are available
- ▶ Floor-mounted Center Console available with movable cup holders, cell phone storage, 12-volt charger, 2 USB ports and hanging file folder capability (Crew cab only)



OPPORTUNITY IS AT YOUR FINGERTIPS

The CV™ Series is ready to go with built-in switch packs to control various application functions. One to four auxiliary switches are available for your specific needs depending on the trim level. Whether you need to control a dump or a flatbed, a switch is ready when you are.



Cab Features	Classic	Diamond
Interior Trim	Soft Touch Vinyl or Cloth	Cloth
Interior Color	Dark Ash or Jet Black	
Available Driver Seats	High-back Split Bench with Headrest, Recline, Fixed Lumbar, Vinyl High-back Split Bench with Headrest, Recline, Manual Lumbar, Cloth 10-Way Power High-back Split Bench with Headrest and Manual Lumbar	10-Way Power High-back Split Bench with Headrest and Manual Lumbar 10-Way Power Bucket (Crew Cab Only), Non-Suspension High Back with Headrest and Power Lumbar
Available Passenger Seats	Two-man, High Back with Headrest in Outboard Position, Center Fold-Down Armrest with Storage, Recline, Vinyl or Cloth, includes 2 USB ports and a 110 Volt outlet Two-man, High Back with Headrest in Outboard Positions and Recline, Center Fold-Down Armrest with Storage and Underseat Storage, Cloth includes 2 USB ports and a 110 Volt outlet High Back with Headrest and Recline, Without Center Section, Vinyl or Cloth	Two-man, High Back with Headrest in Outboard Positions and Recline, Center Fold-Down Armrest with Storage and Underseat Storage, Cloth, includes 2 USB ports and a 110 Volt outlet Non-Suspension, High Back with Adjustable Headrest, 6-way Power Adjustable, Power Lumbar, Cloth (Crew Cab Only)
Rear Bench Seat (Crew Cab Only)	Rear Bench Vinyl or Cloth Omit Rear Bench Seat	Rear Bench Cloth Omit Rear Bench Seat
Gauge Cluster	3.5" Monochromatic Display with Personalization, Speedometer, Odometer, Warning Messages and Vehicle Information	4.2" Color Display with Personalization, Speedometer, Odometer, Warning Messages and Vehicle Information
Air Bag	Driver and Passenger Front Airbags Standard	
Seat Belt Color	Black Available Orange Available Red	
Steering Wheel	4-spoke, 15" Black	4-spoke, 15" Leather Wrapped
Steering Column	Tilt Steering Column	
Center Console	Only available with crew cab, Diamond and bucket seats, or power driver and passenger seats	
End of Frame Auxiliary Work Light Provisions and Toggle Switch	Lighted on Instrument Panel and Wiring Effects for Customer Furnished End of Frame Light	
Roof Mounted Auxiliary Work Light Provisions and Toggle Switch	Lighted in Overhead Console and Wiring Effects for Customer Furnished Roof Mounted Light	
Auxiliary Switches	1 to 4 Latching Switches with 30-Amp Fuses	
Horn	Single, Disc Style Dual, Disc Style	
HVAC	Single Zone Heater and Air Conditioning	
Defroster, Electric Rear Window	Available	
Power Windows	Optional with regular cab, classic trim, Required with crew cab and base trim	Standard
AM/FM Stereo and Infotainment	4.2" color Touch Panel <ul style="list-style-type: none"> • 4 Speaker System • USB, AUX, SD* 7" Color Touch Panel <ul style="list-style-type: none"> • 6 Speaker System • Bluetooth, Seek/Scan, Satellite 	8" Color Touch Panel <ul style="list-style-type: none"> • 6 Speaker System • USB, AUX, SD, Bluetooth, Seek/Scan, Satellite, Voice Activation, Navigation
Compact Disc Player	Available	Required, includes MP3
Interior Sunvisor	Vinyl	Vinyl with Illuminated Mirror for Driver and Passenger Sides
Rearview Mirror	Tilt Mirror	Light Sensitive Tilt Mirror
Rearview Camera	Available	Available
Power Inverter 12V DC to 110V AC	Available	Required
Remote Start	Not Available	Available Remote Start Keyfob includes Theft Deterrent System



CAB CONFIGURATIONS



CV™ SERIES REGULAR CAB

SPECIFICATIONS

GVWR

- ▶ 4x2: 16,000 - 23,500 lbs.
- ▶ 4x4: 17,500 - 23,000 lbs.

Models/BBC/BA

- ▶ CV515: 115" BBC, 34" BA

Cab Configurations

- ▶ Regular Cab
- ▶ Crew Cab

Frame

- ▶ High Strength, Low Alloy Steel 50,000 PSI

Front End

- ▶ Tilting Fiberglass Hood with 3-Piece Construction

Fender Extensions

- ▶ Molded in black
- ▶ Painted

Grille

- ▶ Molded Dark gray
- ▶ Chrome with Chrome Headlight Bezels

Grille Bug Screen

- ▶ Available Bug Screen Mounted Behind Grille

Grille Ember Screen

- ▶ Available Mounted behind Grille to Keep Hot Embers out of Engine and HVAC Air Intake System

Radiator Stone Guard

- ▶ Available, mounted to front bumper

Bumper

- ▶ Full Width, Aerodynamic, Steel, Painted Gray
- ▶ Full Width, Aerodynamic, Steel, Chrome Plated
- ▶ Full Width, Aerodynamic, Steel, Painted Black

Tow Hooks

- ▶ Available (2) Frame Mounted Tow Hooks

Bumper Extension

- ▶ Available 4" Front Bumper Extension

Cab Access Steps

- ▶ One Painted Step per Door - standard
- ▶ Available Bright Aluminum Steps

Cab Mirrors

- ▶ (2) Wide Load, Manual Folding and Extending, Black Head, Mounting Bracket and Arm
- ▶ (2) Wide Load, Manual Folding and Extending, Black Head, Mounting Bracket and Arms, Heated Head, Turn Signal Indicator Located in Mirror, Power Operated
- ▶ (2) Wide Load, Manual Folding and Extending, Bright Head, Black Mounting Bracket and Arms, Heated Head, Turn Signal Indicator Located in Mirror, Power Operated





CV™ SERIES CREW CAB

Cab Glass

- ▶ All Windows Solar Absorbing Tint
- ▶ Deep Tinted, Rear Glass Only on Standard Cab, Rear Doors and Rear Glass on Crew Cab

Wheelbase Options

- ▶ Regular Cab
 - 141" (60" CA)
 - 165" (84" CA)
 - 189" (108" CA)
 - 201" (120" CA)
 - ▶ Crew Cab
 - 175" (60" CA)
 - 199" (84" CA)
- | |
|------------------|
| • 219" (138" CA) |
| • 231" (150" CA) |
| • 243" (162" CA) |
| • 235" (120" CA) |

Axle Configurations

- ▶ 4x2, 4x4

Front Axle

- ▶ 4x2
 - Dana Spicer 6,000 lbs.
 - Dana Spicer 7,000 lbs.
 - Dana Spicer 8,000 lbs.
- ▶ 4x4
 - Dana Spicer 7,500 lbs.

Front Suspension

- ▶ 4x2
 - Taper Leaf Shackle Type 6,000 lbs. with Shock Absorbers
 - Taper Leaf Shackle Type 7,000 lbs. with Shock Absorbers
 - Parabolic Taper Leaf 8,000 lbs. with Shock Absorbers
- ▶ 4x4
 - Parabolic Taper Leaf 7,500 lbs. with Shock Absorbers

Front Stabilizer Bar

- ▶ Available Front Stabilizer Bar

Front Brakes

- ▶ Hydraulic Disc, Quadraulic Four 64mm Diameter Pistons

Rear Axle

- ▶ Dana Spicer S14-110 Single Reduction, 10,000 lbs.
- ▶ Dana Spicer S14-110 Single Reduction, 11,000 lbs.
- ▶ Dana Spicer S14-110 Single Reduction, 13,500 lbs.
- ▶ Dana Spicer S16-130 Single Reduction, 15,000 lbs.
- ▶ Dana Spicer S16-130 Single Reduction, 15,500 lbs.

Rear Suspension

- ▶ Spring, Vari-Rate: 11,000 - 15,500 lbs.
- ▶ Air, International® Ride Optimized Suspension (IROS): 12,000 - 15,500 lbs (4x2 only).

Air Suspension Control Valve

- ▶ Available Pressure release Control in Cab

Rear Axle Ratio

- ▶ 4x2: 4.10, 4.30, 4.56, 4.88
- ▶ 4x4: 4.30

Rear Brakes

- ▶ Hydraulic Disc, Quadraulic Four 64mm Diameter Pistons



SPECIFICATIONS CONTINUED

Differential Lock

- ▶ Available Dana Spicer Truetrac Torque Proportioning Limited Slip Differential

Electrical

- ▶ Batteries
 - (2) Batteries: 1100 – 1300 CCA
 - (3) Batteries: 2250 CCA
- ▶ Alternator
 - Denso SC2 Brush Type 150 Amps
 - Denso SC6 Brush Type 220 Amps
 - Denso SC6 Dual Brush Type 150 and 220 Amps
- ▶ Jump Start Stud
 - Available Remote Mounted
- ▶ Headlights
 - Halogen Composite Aero with Chrome Trim Bezel
 - Halogen Composite Aero with Black Trim Bezel
- ▶ Fog lights
 - Available (2) Clear Lens, Halogen, Rectangular
- ▶ Body Builder Wiring
 - Rear of Frame; Includes One Sealed Connector for Separate Ground/Backup/ Left and Right Hand Turn, Left and Right Hand Tail/Stop/ Accessory Power and Combined for Left and Right Hand Stop/Turn
 - Back of Cab at Left Frame; Includes One Sealed Connector for Separate Ground/Backup/Left and Right Hand Turn, Left and Right Hand Tail/Stop/Accessory Power and Combined for Left and Right Hand Stop/Turn

Battery Box

- ▶ Steel with Plastic Cover, 2 Batteries Parallel to Rail, 28" Wide, Mounted Left Side Under Cab

Brake System

- ▶ Hydromax with Traction Control and Four Channel ABS

Trailer Brake Control

- ▶ Available Integrated Trailer Brake Control

Trailer Connection Socket

- ▶ Available Mounted at Rear of Frame, Wired for Turn Signals Combined with Stop, Compatible with Trailers That Use Combined Stop, Tail, Turn Lamps

Steering

- ▶ Bosch: S2 8014 Plus

Fuel Tanks

- ▶ Single, Rectangular 25 Gallon, Mounted Between Rails Forward of Rear Axle
- ▶ Single, Rectangular 40 Gallon, Mounted between Rails Behind Rear Axle
- ▶ Dual, Rectangular 25 Gallon and 40 Gallon

Diesel Exhaust Fluid Tank

- ▶ 6.75 Gallon, Frame Mounted Outside Right Rail, Under Cab

Engine

- ▶ International® 6.6 V8 Turbocharged Diesel Engine
 - 350 hp @ 2700 RPM
 - 700 lb. - ft. torque @1600 RPM
 - 2900 RPM Governed Speed



Engine Exhaust Brake

- ▶ Available Engine Exhaust Brake

Exhaust System

- ▶ Horizontal, Frame Mounted, Right Side Under Cab
- ▶ Tailpipe
 - WB greater than 141": Straight tailpipe, exits right or available left side ahead of rear axle
 - 141" WB: Over rear axle, exits behind rear axle

Hand Throttle

- ▶ Available Engine Speed Control for PTO

Fan Drive

- ▶ Viscous Screw On Type, Rear Tether, Electronically Controlled

Engine Block Heater

- ▶ Available 120 Volt 800 Watt

Heater Hoses

- ▶ Available Silicone Heater Hoses

Keyless Entry System Remote

- ▶ Available with Panic Alarm and Horn Beep Lock Confirmation, Includes Two Key Fob Transmitters

Transmission

- ▶ Allison 6-speed: 1700, 1750, 2700 Series
 - Available Vocational Codes: HS, RDS, EVS, MH
 - With or Without PTO Provision
 - Includes Park Pawl
 - With Double Overdrive

PTO

- ▶ Available Transmission-mounted, Right Side (requires PTO-equipped transmission)

Transfer Case (4x4)

- ▶ Meritor: 3203, 2-speed, Gear Drive with Electric Shifting Controls, with optional skid plate

Transfer Case Skid Plate

- ▶ Frame-mounted Protective Plate (available with off-road package)

Wheels

- ▶ Powder Coat Steel, Accuride 50180 Disc, 19.5x6.75 Rims, 4-Hand Hole, 8-Stud, 275mm BC, Hub-Piloted, Flanged Nut, with Steel Hubs
- ▶ Polished Aluminum, Accuride 29695 DISC, 19.5x6.75 Rims, 8-Stud, 275mm BC, Hub-Piloted, Flanged Nut, with Steel Hubs

Tires

- ▶ Goodyear
- ▶ Continental

WARRANTY

- ▶ Base Chassis Warranty: 3/36k
- ▶ Base Engine Warranty: 5/100k
- ▶ Transmission Warranty: 5/Unlimited





Note: The information and conclusions contained herein are believed to be correct at time of publication, but do not necessarily apply to similar vehicles with different specifications or with production dates after the production of this publication. Vehicles with different specifications or later dates of production may yield different results. Vehicle specifications are subject to change without notice. TAD18038 7/2020 ©2020 NAVISTAR Inc. All rights reserved. All marks are trademarks of their respective owners.